

**TOWN OF GLASTONBURY  
 BID NO. GL-2026-22  
 50 NYE ROAD PARKING LOT IMPROVEMENTS LANDSCAPING, FENCING AND TURF  
 ESTABLISHMENT INSTALLATION**

**ADDENDUM NO. 1  
 MARCH 27, 2026**

**BID DUE DATE: MARCH 31, 2026 11:00 A.M.**

The attention of bidders submitting proposals for the above-referenced project is called to the following Addendum to the specifications. The items set forth herein, whether of omission, addition, substitution or other change, are all to be included in and form a part of the proposed Contract Documents for the work. Bidders shall acknowledge this Addendum in the Bid Proposal by inserting its number on Page BP-1.

Make the following modifications to the Contract Documents:

**SPECIAL PROVISIONS: The special provision for ITEM # 0906006A 10" x 10" TIMBER POST is hereby replaced with the attached revised special provision (see pages SP-13 to SP-14). Revisions to the previous specification are highlighted in red text.**

**QUESTIONS AND ANSWERS**

Q1-1:	Please identify the anticipated start date for this contract?
A1-1:	As outlined in the specifications, the anticipated start date will need to be coordinated with Town staff with a mutually agreed upon start date.
Q2-1:	Section 1.10 Environmental Compliance- Please identify who will supply, install, and maintain Exclusionary fencing for the Box Turtle and Green Snake for this contract?
A2-1:	The Town of Glastonbury personnel will be furnishing and maintaining the exclusionary fencing. Contractors should be aware and conform to these requirements while performing the contracted work.
Q3-1:	Item #0906006A- 10" x 10" Timber Post- Please identify the length of the supplied posts?
A3-1:	Attached special provision and detail for this item has been revised to reflect a 10" x 10" x 6' Timber Post.
Q4-1:	Item #0906006A- 10" x 10" Timber Post- Please identify the depth the post is to be set in the ground?
A4-1:	Timber post shall be set below grade a minimum of 42" per attached revised specification and detail.
Q4-1:	Item #0906006A- 10" x 10" Timber Post- The specification notes "Backfill for all dug holes shall be approved material". Please identify the "approved material" that is to be used for backfilling?
A4-1:	Approved backfill for the timber post can be native material free of large stones and organics.

NOTE: This Addendum consists of 4 pages including 3 additional pages for the revised Special Provision and Detail described above.

**50 NYE ROAD PARKING LOT IMPROVEMENTS  
LANDSCAPING, FENCING AND TURF ESTABLISHMENT  
SPECIAL PROVISIONS- **ADDENDUM NO. 1****

**BID #GL-2026-22**

**ITEM # 0906006A      10" X 10" TIMBER POST**

**Description:**

The work under this item shall consist of furnishing and installing 10" X 10" Timber Posts to the dimensions and layout as shown on the plans and details or as directed by the Engineer.

**Materials:**

All timbers to be utilized shall be pressure treated

**WOOD TREATMENT:** Shall comply with American Wood Preservers Association (AWPA) standards for category UC4B-Ground Contact (Heavy Duty). The treating plant shall imprint legible symbols in the end of all timber treated, indicating the name of the treating company and the type and year of treatment in accordance with current AWPA standards.

**TIMBERS:** Shall be Rough Sawn, No. 2 or better Southern Yellow Pine timbers.

10" x 10" x 6' Timber posts shall be suitable material for ground contact.

**CONCRETE:** Shall conform to ConnDOT Form 819, Section M.03, Article M.03.02, Table M.03.02-1, Class PCC3360- 3,300 PSI.

**Construction Methods:**

Do not begin installation before completion of final grading.

Contractor is required to coordinate the work related to these items with all subcontractors and/or Town Entities to ensure timely installation.

In areas where no existing underground utilities are present, post holes shall be drilled into firm undisturbed or thoroughly compacted soil **to a minimum depth of 42"**. The bottoms of dug holes shall be thoroughly rammed so that the posts have a stable foundation. Backfill for all dug holes shall be approved **native** material and is to be machine-tamped in 4-inch layers in such a way as not to shift the posts from the correct alignment.

Align each post both vertically and laterally. Secure in position during backfilling operations. Posts shall be set at a constant vertical alignment above finished grade. Posts shall be set at a constant distance from edges of pavements as depicted on the details or as directed by the Engineer.

Exposed top edges of all timbers shall be chamfered 1" and lightly sanded to produce eased edges.

Electrical conduits for parking lot illumination will be installed a minimum of 3 feet away from proposed timber post alignment to facilitate post installation. Timber post installation in close proximity of the light pole bases may require hand excavation methods due to the close proximity of electrical conduits in these areas.

Prior to installation of the Timber Posts, Contractor shall facilitate mark-out of the any installed electrical conduit within the project limits.

Clean up during installation and upon completion of work. Remove from site all waste and excess materials, debris, tools, and equipment.

**Method of Measurement:**

The work will be measured for payment by the accepted number of each "10" x 10" Timber Post", completed and accepted.

**50 NYE ROAD PARKING LOT IMPROVEMENTS  
LANDSCAPING, FENCING AND TURF ESTABLISHMENT  
SPECIAL PROVISIONS- **ADDENDUM NO. 1****

**BID #GL-2026-22**

Excavation, Excavation by hand and backfilling will not be measured for payment, but its cost shall be included in the bid price for each "10" x 10" Timber Post".

**Basis of Payment:**

The work under the item will be paid for at the contact unit price per each "10" X 10" Timber Post" as listed in the bid proposal, completed in place and accepted by the Engineer. Said unit price shall include all excavation, hand excavation, backfill, compaction, disposal of excess material, restoration of disturbed areas, all materials, equipment, tools, labor, and work incidental thereto.

<b><u>Item No.</u></b>	<b><u>Description</u></b>	<b><u>Unit</u></b>
906006A	10" X 10" TIMBER POST	EA.

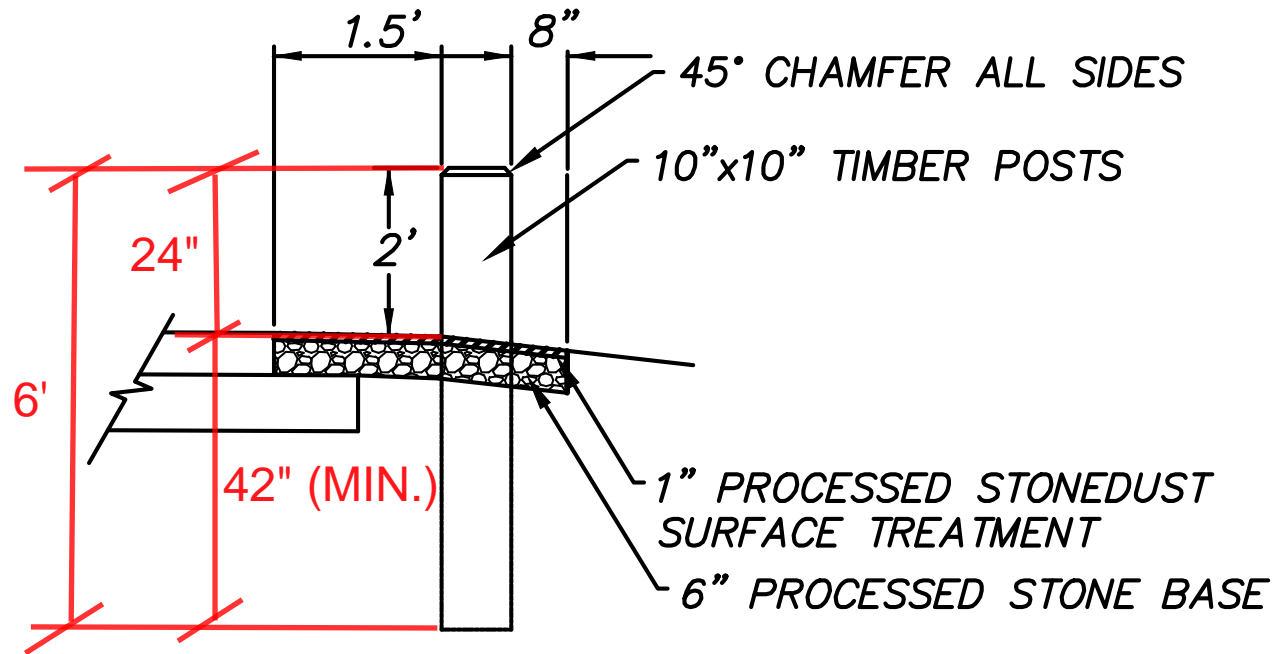

TIMBER POST INSTALLATION DETAIL  
SCALE : N.T.S.